

# NE-21521

## 2100 Watt\* Commercial Microwave Oven

### Technical Specifications

- Power source:** 60Hz, Single phase

---

- Receptacle required:** NEMA 6-20R 

---

- Frequency:** 2,450MHz

---

- Required power:** 208/230 V Single Phase

---

- Output\*:** 2100 Watts

---

- Outer dimensions:** 16 5/8" w x 20" d x 13 3/16" h

---

- Cavity dimensions:** 13" w x 12" d x 6 7/8" h

---

- Net weight:** 68 lbs.

---

- Shipping weight:** 73 lbs.

---

- Shipping box size:** 19 15/16" w x 24 1/8" d x 16 7/8" h, 4.7 ft<sup>3</sup>

---

- Warranty:** 1 Year Parts, Labor and Travel/Shipping



### To specify a Panasonic Commercial Microwave Oven:

The NE-21521 Commercial Microwave Oven meets or exceeds all safety performance and sanitation standards set for commercial food service microwave ovens by: UL, HHS, FCC and NSF.

Plus, oven shall have output power 2100 Watts\*, Independently controlled top and bottom energy feed, Grab & Go door handle, Automatic Voltage Selector, patented Safety Door Seal System, 90 programmable memory pads, 5-stage cooking, 15 power levels, LCD digital display w/countdown, energy efficient LED cavity lighting, programmable lock, self-diagnostics, oven cycle counter, stackable, video training and Chef/Test Kitchen technical support.

\* I.E.C. 705-88 Test Procedure. Specifications subject to change without notice.

### Receptacle Required

2 Pole  
3 Wire

**NEMA Reference:**  
Receptacle: 6-20R  
Plug: 6-20P

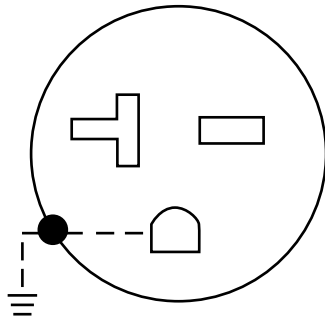

**ADA Compliance**  
§4.28.2 ((CFR) –  
28CFR Part 36)  
“For Alarms”.

§4.27 “For controls  
and operating  
mechanisms”.

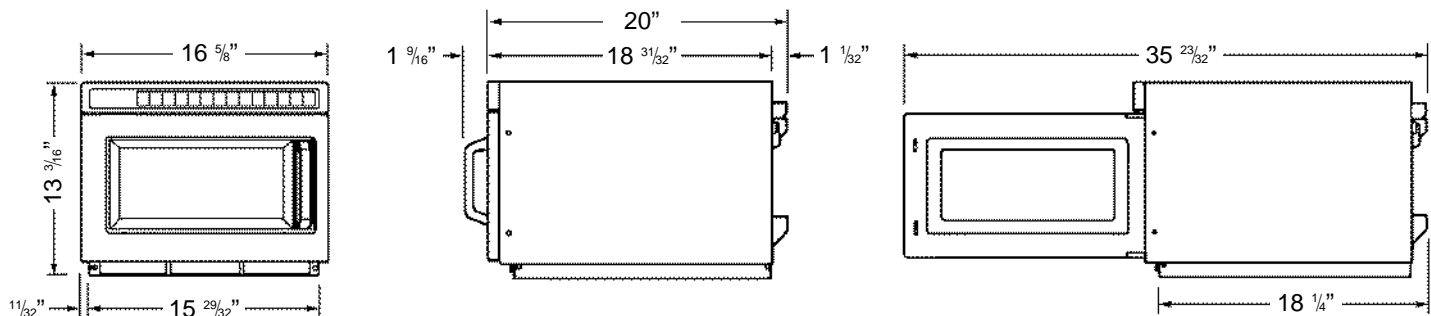

**Panasonic Appliance & Commercial Group**  
Division of PNA  
Executive Offices:  
Two Riverfront Plaza, 8th Fl (08N-120) Newark, NJ 07102-54900  
Toll Free: 1-888-350-9590  
www.panasonic.com/cmo