

KWH GALLEY WATER WASH HOOD

With Capture Jet technology



MATERIALS

PART	MATERIAL	NOTE
Front and side walls	Stainless steel EN 1.4301 (AISI304)*	Available as an option: EN 1.4404 (AISI316L)
Main body	Stainless steel EN 1.4301 (AISI304)**	Available as an option: EN 1.4404 (AISI316L)
Light fixture	Painted steel	-
Wash piping	Stainless steel, brass	-
Cables	Halogen free	-

* Thickness 2,0 mm

** Thickness 1,25 mm

KWH CONSTRUCTION

The KWH hood comprises a Capture Jet™ air supply module, a light fixture, adjustment dampers, airflow measurement taps and KSA grease filters. All parts of the hood are manufactured from polished stainless steel EN 1.4301 (AISI304). The joints at the lower edges of the device are watertight. A drain pipe connection is fitted into the exhaust plenum in order to enable removal of the grease and dirt extracted by the KSA multi-cyclone filters and to drain the washing water. The Capture Jet™ supply plenum is thermally insulated through the use of mineral wool material to prevent condensation on the inner face above the cooking equipment.

KWH PRODUCT OPTIONS

- Non-standard spigots: choice of size and position
- UV-light filtration - a combination of KSA filter, mesh filter and ultraviolet-light technology
- EN 1.4404 (AISI316L) construction
- Certified fire damper manufactured of EN 1.4301 (AISI304) or EN 1.4404 (AISI316L)
- Wet chemical fire suppression system
- M.A.R.V.E.L. demand-based ventilation system

APPLICATIONS

Halton KWH is a galley water wash hood for use in marine & offshore applications. The highly efficient KWH hood uses Halton Capture Jet™ technology, which allows the hood to operate with up to 30% lower exhaust airflow rates than traditional hoods. The KWH galley hood automatically washes down the grease filters without the need for removal of the filters from the hood. The washing cycle, operated by a control cabinet CCW-M or WR (see separate brochure), is fully automatic and programmable for use in different operating conditions. The washing process can be manually overridden, when required.

FEATURES

- The design follows USPHS guidelines
- Automatic periodic cleaning of the exhaust plenum and KSA grease filters (and UV tubes when applicable)
- Minimal maintenance requirements, reducing the work load for personnel cleaning the filters
- High level of hygiene facilitated
- Prevention of the build-up of grease deposits, which pose a serious fire hazard
- Halton Capture Jet™ technology, reducing the required exhaust airflow rate and improving the capture and containment efficiencies of the hood, while reducing energy use
- High-efficiency grease filtration using Halton KSA multi-cyclone filters
- Supplied as standard with lighting, balancing dampers for both capture and exhaust air and T.A.B.™ airflow measurement taps, which allow accurate and effective balancing of airflows, and efficient commissioning
- Stainless steel, welded construction

GENERAL KWH DRAWINGS

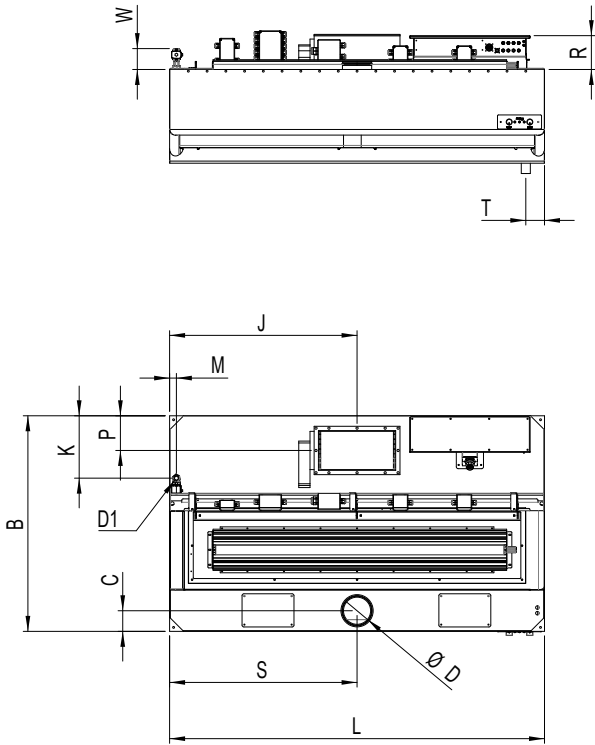

KWH DIMENSIONS (mm)			
A	195	L	1000-3000
B	1100-1900	M	37
C	110	P	185
D	100-200	S	1/2L
D1	3/4"	T	100-200
H	350	U	70
H1	500	R	185
J	1/2L	V	max 50
K	332	W	~130

Note: Maintenance / light fixture hatch is as big as the construction allows.
 Note: Minimum length with UV-light technology is 1200 mm.

KWH PARTS

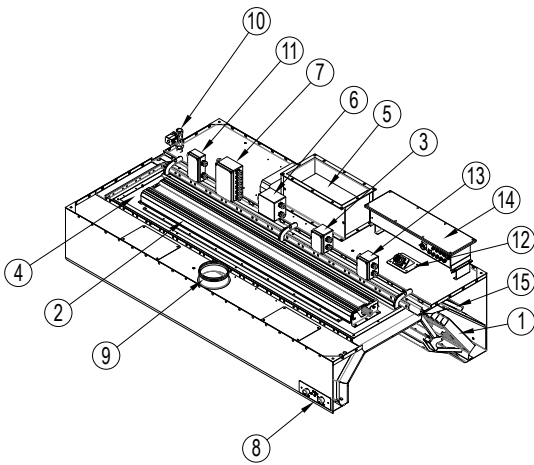

PARTS: 1 KSA grease filters, 2 Lighting fixture, 3 Lighting fixture power supply junction box, 4 Maintenance hatch, 5 Exhaust air connection, fire damper or shut-off damper (available as an option) and adjustment damper, 6 Fire damper junction box, 7 Actuator power and fuse info junction box, 8 Damper switch and indication (available as an option), 9 Capture air connection and adjustment damper, 10 Water wash piping connection R3/4" (G3/4" solenoid valve as an option), 11 Washing solenoid valve junction box, 12 UV system, available as an option, 13 UV power supply junction box, available as an option, 14 UV control junction box, available as an option (location may vary), 15 Mesh filter, available as an option

WEIGHTS

KWH HOODS (KG)

B/L	1200	1600	2000	2500	3000
1100	105	127	148	176	203
1300	110	133	155	184	212
1500	116	140	162	193	221
1700	122	146	169	201	230
1900	127	153	177	209	240

The above table represents an indication of different size of average KWH hoods. Weight does not include fire damper.

KWH HOODS WITH UV-LIGHT TECHNOLOGY (KG)

B/L	1200	1600	2000	2500	3000
1100	145	172	198	232	264
1300	151	179	205	240	274
1500	157	185	212	249	283
1700	162	192	220	257	292
1900	168	198	227	265	301

The above table represents an indication of different size of average KWH hoods with UV-light technology. Weight does not include the fire damper.

KWH FUNCTION

1. Capture air enters the Capture Jet™ plenum.
2. Contaminated air and heat rises from the cooking appliances.
3. Contaminated air is directed into the hood by Halton patented Capture Jet™ technology.
4. KSA multi-cyclone filters remove grease and contaminants from the air stream with the aid of centrifugal effect. According to independent laboratory tests KSA is the most efficient mechanical grease filter on the market.
5. Mesh filter balances the airflow inside exhaust plenum and apply more filtration to the air. Together with KSA filter this doubles filtration efficiency. Mesh filter is available as an option.
6. UV-light filtration: Most grease particles are first filtered with two-stage mechanical filtration. Remaining grease is then eliminated with Halton's ultraviolet light technology. UV-filtration is available as an option.
7. Cleaned exhaust air contains small amounts of Ozone which further cleans the ducts downstream. All excess Ozone converts back into Oxygen.
8. At scheduled times the washing control cabinet stops the hood operation and begins a washing cycle. Hot water with mild detergent is pumped into the hood spray nozzles, washing the essential parts of the exhaust plenum including UV-lights and filters.
9. The waste from the washing cycle is drained from the hood via the drain connection.

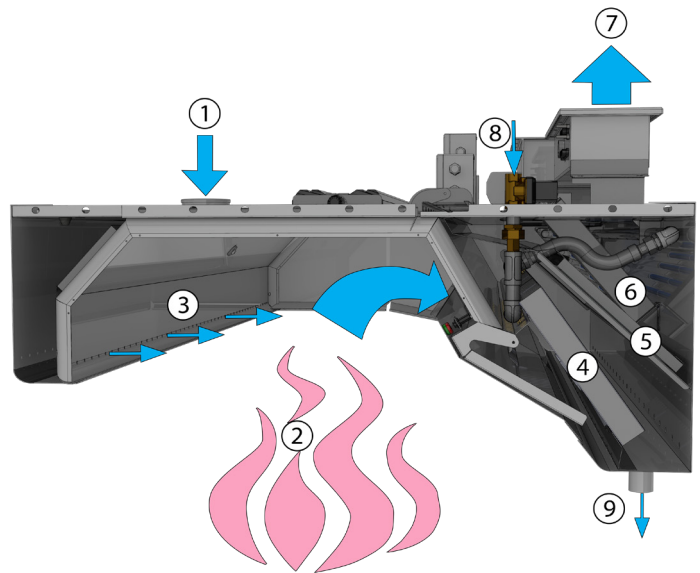

SUGGESTED SPECIFICATIONS

The water wash galley hoods shall be constructed from stainless steel EN 1.4301 (AISI304). The galley hoods shall be supplied complete with outer casing / main body, capture jet plenum, airflow measurement taps, supply and exhaust air spigot connections with adjustment damper, maintenance hatch, light fixture, capture air jet, grease filters, drain connection, automatic washing system controlled by separate control cabinet with interfaces to ships safety systems. Classified fire damper in each exhaust connection. The manufacture of all galley hoods shall be controlled by ISO 3834-2:2005, ISO 9001, 14001 and OHSAS 18001 standards. The design of hoods shall follow USPHS guidelines.

CONSTRUCTION

All parts shall be constructed of stainless steel sheet EN 1.4301 (AISI304) (thickness 1.25-2.0 mm) with a polished finish. The inside corners of the hood are rounded for easy cleanability according to USPHS guidelines. The joints at the lower edges of the device are welded watertight. All visible screws are thumb screw type. The hood is equipped with a drain connection for removing the dirty water. There is a maintenance hatch in each hood for easy access above the hood.

WASHING MODULE

Grease filters shall have an automatic washing cycle utilising warm water and detergent via nozzles. The mixing of the detergent occurs within a separate control cabinet. The wastewater shall be removed from the hood by a direct drain connection. The casing of the control cabinet shall be constructed of stainless steel sheet EN 1.4301 (AISI304).

CAPTURE JET PLENUM

The Capture Jet™ plenum shall be insulated with sealed mineral wool. Plenum can be accessed through a maintenance hatch(es).

CAPTURE JET SYSTEM

The hood shall be designed with Capture Jet™ technology to reduce the exhaust airflow rate required and increase the capture and containment efficiencies of the hood, while reducing energy use.

AIRFLOW MEASUREMENT TAPS

Measurement taps shall be located on top of the hood for capture air and exhaust air measurement.

DEMAND BASED FILTRATION

Halton KSA filter

- Minimisation of grease deposits in the ducts
- Enhanced hygiene and safety

The KSA grease filters shall be constructed of stainless steel EN 1.4301 (AISI304). The grease filters shall be supplied in modular size of 500x330x50 mm and shall be removable via two folding handles. The grease filters shall have a honeycomb design in order to allow high grease filtration efficiency with the aid of centrifugal effect in filter honeycombs.

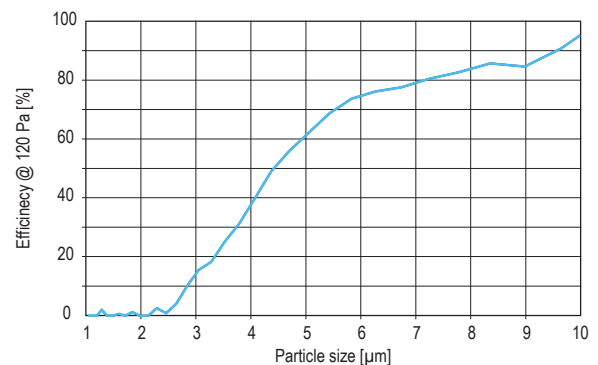
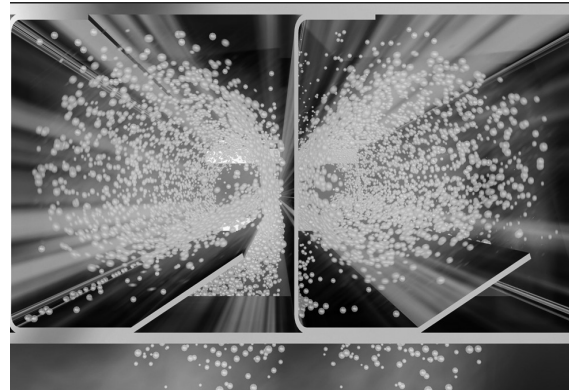

Mechanical filtration is recommended to be used in hoods with low utilization rate and cooking process producing mainly large grease particles (> 8 microns), e.g. food prepared with gas fryers, griddles and broilers (source ASHRAE).

UV-light filtration

Halton's UV-light technology is the most efficient solution for hoods with medium to high utilization rate and cooking processes producing all sizes of grease particles, e.g. food prepared with electric ranges, griddles and all type of broilers.

In the UV-light concept, most of the grease particles are first filtered with mechanical filtration (type KSA). The mesh filter behind the KSA spreads the airflow and the remaining grease particles inside the hood chamber. This

increases filtration efficiency up to 50% with grease particles sizes between 5-8 microns. The remaining grease is then eliminated with ultraviolet-light technology, resulting in a clean exhaust ductwork.

Halton's UV-light technology breaks remaining small grease particles into smaller molecular units. Ozone generated by the UVC lamps reacts with solid and vaporised greases. The resulting substance will not stick to the ductwork or fans, this helps to reduce a serious fire risk and expensive cleaning of the ducts.

DUCT CONNECTIONS

The duct connections and adjustment dampers for supply and exhaust air shall be constructed from stainless steel. The dampers shall be adjustable.

LIGHT FIXTURES

Each hood shall be delivered with a fluorescent light fixtures or LED light fixtures providing approx. an average illuminance of 500 lux at the work surfaces of the cooking appliances.

The light fixtures shall be suitable for a single-phase 230-VAC power supply and shall be manufactured to be of protection class IP67.

The ballast and capacitor shall be located within the light frame. The core electric cables connecting the light fixture to the junction box shall be provided. The light fixture shall be installed on a hinged maintenance hatch, allowing access to the hood roof.

FLUORESCENT LIGHT FIXTURE SIZES

HOOD DIMENSION	LENGTH	WIDTH
L < 1250 mm, 2x24 W	720 mm	220 mm
L ≥ 1250 mm, < 2000 mm, 2x39 W	1020 mm	220 mm
L ≥ 2000 mm, 2x49 W	1620 mm	220 mm

LED LIGHT FIXTURE SIZES

HOOD DIMENSION	LENGTH	WIDTH
L < 1250 mm, 1x28 W	720 mm	175 mm
L ≥ 1250 mm, < 2000 mm, 1x42 W	1020 mm	175 mm
L ≥ 2000 mm, 1x69 W	1620 mm	175 mm

MAINTENANCE HATCH

Each hood shall be provided with a maintenance hatch made of stainless steel EN 1.4301 (AISI304) with a shock-resistant plastic window. The heat tolerance of the window shall be up to +115 °C. The hatch shall be easily opened and closed.

The maintenance / light fixture hatch is as big as the construction allows.

AIRFLOW MEASUREMENT

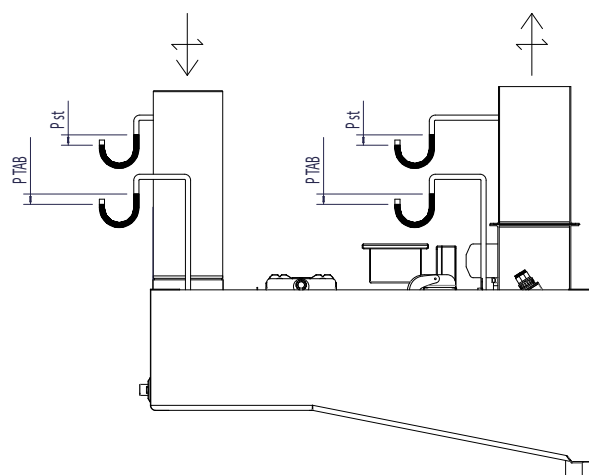

ΔP_{st} = Static pressure loss

ΔP_{TAB} = TAB pressure for airflow rate measurement

70, 100 = Damper opening in %

PRESSURE DROP AND SOUND DATA WITH RECOMMENDED EXHAUST CONNECTION SIZE

KWH, section 1000, static pressure loss and sound data

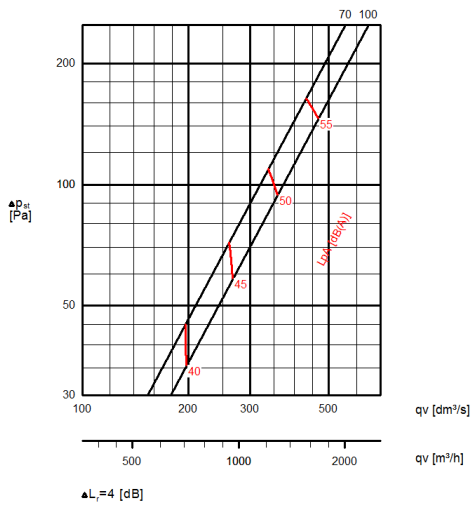

KWH, section 1500, static pressure loss and sound data

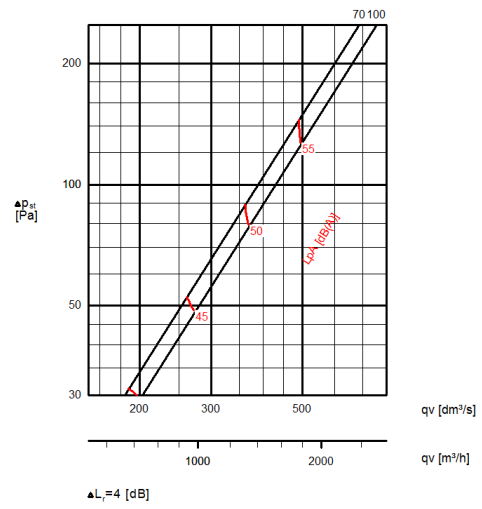

KWH, section 2000, static pressure loss and sound data

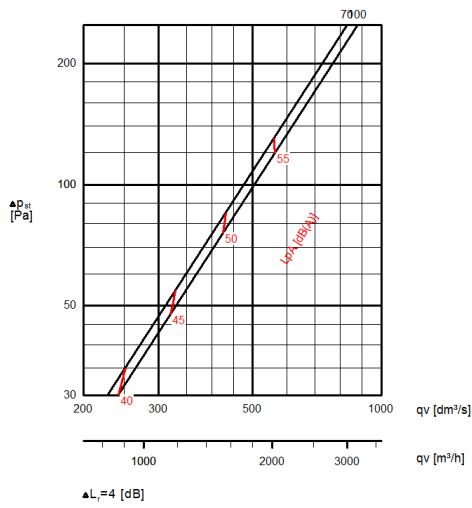

KWH, section 2500, static pressure loss and sound data

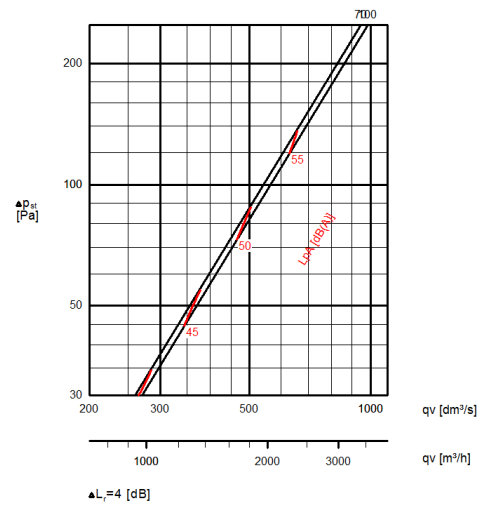

KWH, section 3000, static pressure loss and sound data

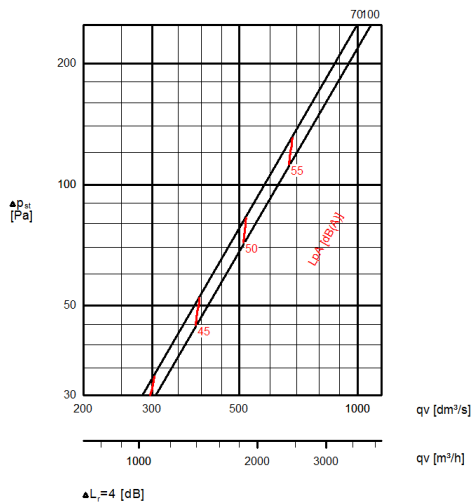

M10Y2018/Halton Marine reserves the right to alter products without notice.

PRESSURE DROP AND SOUND DATA WITH RECOMMENDED EXHAUST CONNECTION SIZE

KWH with UV-light technology, section 1000, static pressure loss and sound data

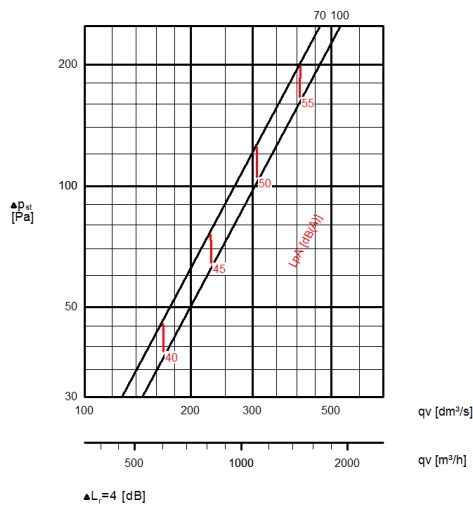

KWH with UV-light technology, section 1500, static pressure loss and sound data

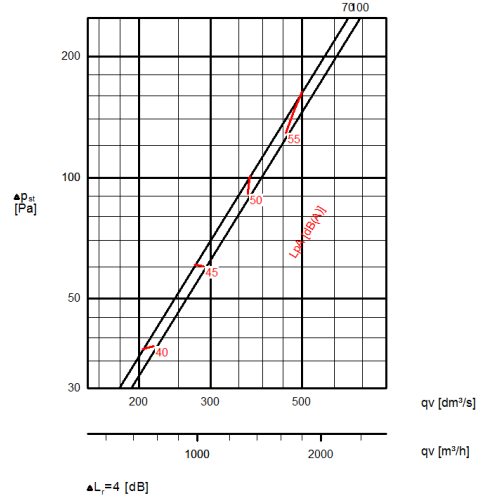

KWH with UV-light technology, section 2000, static pressure loss and sound data

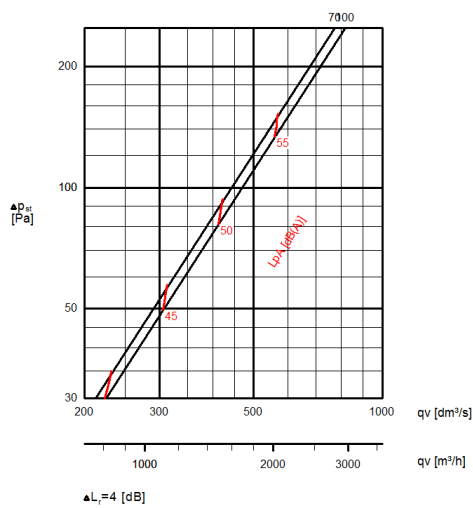

KWH with UV-light technology, section 2500, static pressure loss and sound data

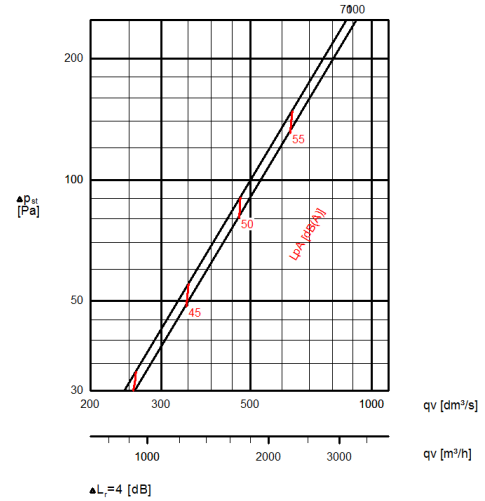

KWH with UV-light technology, section 3000, static pressure loss and sound data

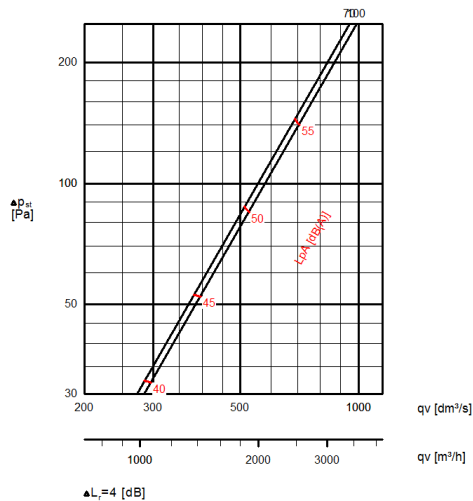

Δp_{st} = exhaust static pressure loss
 70, 100 = damper opening in %
 ΔL_r = room attenuation

PRESSURE DROP AND SOUND DATA WITH RECOMMENDED CAPTURE CONNECTION SIZE

KWH, section 1000, static pressure loss and sound data

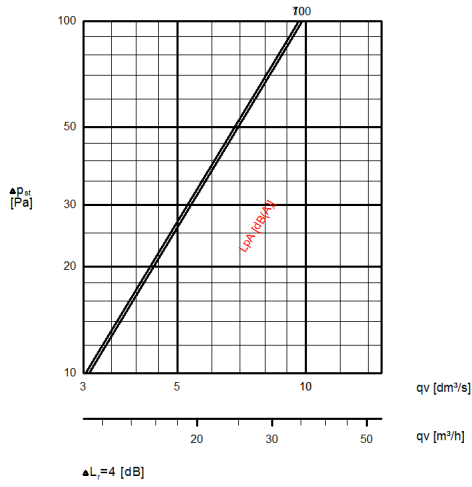

KWH, section 1500, static pressure loss and sound data

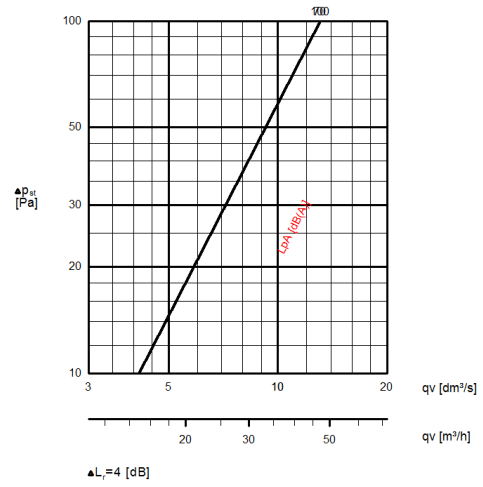

KWH, section 2000, static pressure loss and sound data

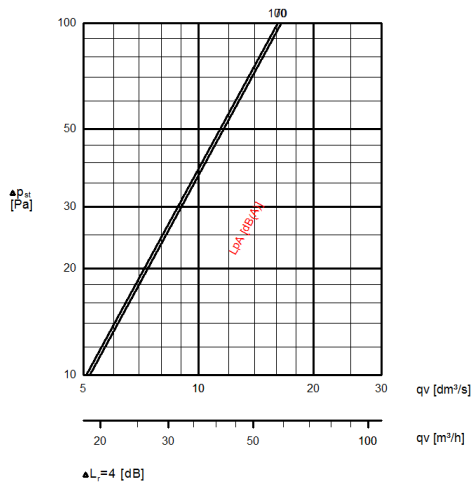

KWH, section 2500, static pressure loss and sound data

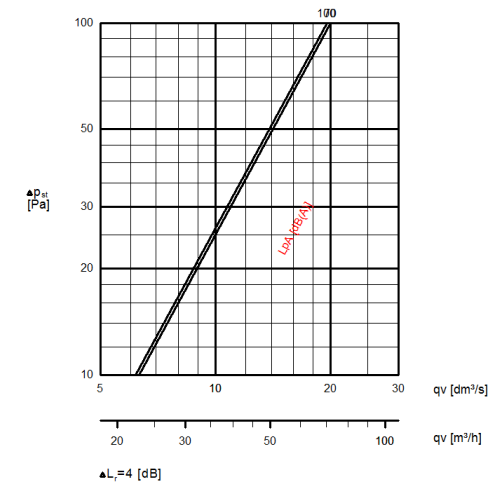

KWH, section 3000, static pressure loss and sound data

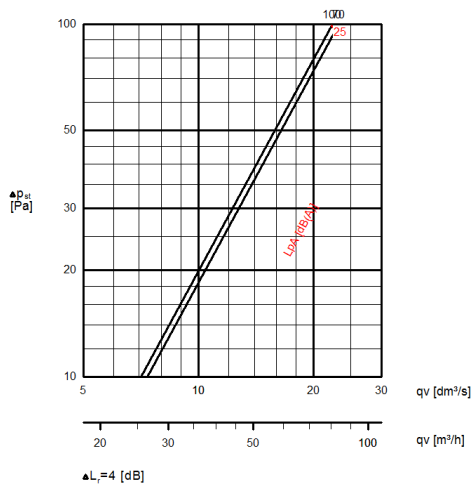

Δp_{st} = capture static pressure loss
 70, 100 = damper opening in %
 ΔL_r = room attenuation

EXHAUST AIRFLOW RATE MEASUREMENT USING K FACTORS

KSA (NUMBER OF FILTERS)	KWH HOOD k factor [m ³ /h]	KWH HOOD k factor [l/s]	KWH WITH UV k factor [m ³ /h]	KWH WITH UV k factor [l/s]
1	116,3	32,3	77,6	21,5
2	142,9	39,7	117,9	32,8
3	169,4	47,1	158,3	44,0
4	203,2	56,4	198,0	55,0
5	237,3	65,9	232,5	64,6
6	269,2	74,8	259,6	72,1

With the T.A.B. pressure measurement, it is also possible to check the exhaust airflow with the following formula. Above values are with recommended exhaust connection size.

$$q_{v,e} = k \times \sqrt{\Delta P_{TAB} [\text{Pa}]}$$

$q_{v,e}$ = Airflow

k = K-factor

ΔP_{TAB} = Pressure difference

RECOMMENDED EXHAUST AIRFLOW FOR KWH

NUMBER OF KSA FILTERS	MINIMUM l/s	MAXIMUM l/s	MINIMUM m ³ /h	MAXIMUM m ³ /h
1	130	201	468	724
2	259	402	932	1447
3	389	602	1400	2167
4	518	803	1865	2891
5	648	1004	2333	3614
6	778	1205	2801	4338

Note: KSA filter size 500x330x50 mm

M10Y2018/Halton Marine reserves the right to alter products without notice.