

## FV 60.2

### Utensil washer



FV 60.2 – an outstanding, premium class warewasher

## FV 60.2

# Front-loader for bulky dishware

This new glass and dishwashing machine is perfectly designed to meet the needs of bakeries and butchers, thanks to its performance and versatility. Elegantly compact on the outside, its true space can only be appreciated after opening the door: 600 mm of loading and washing depth ready for cleaning (almost) anything. A concept setting new standards in its class.

A genuine, industrial, all-round washing unit to meet a wide range of requirements. Washes not only dishes and glasses but also - a first for this category - large transport containers, baskets, and trays of up to 600 x 400 mm. Therefore perfectly suited to bakeries with their own cafés or butcher's shops that also offer snacks, for example. Its attractive equipment features from the easy to use premium class also earn it top marks. From the user-friendly and intelligent

fully electronic control and *AktivPlus* drain filter system through to the Aqua-Stop-System ASS, or the soft start to prevent damage to your dishware as well as the self-cleaning feature and much, much more ... An attractive dishwashing concept for your business, designed to ensure not only perfect cleaning quality but also impressive economy in use. And all this for a reasonable price.



# Features that deliver real benefits



The clean solution

A few of the features and benefits that clearly demonstrate the outstanding sophistication of the FV 60.2

- **Clear entry dimensions of 420 x 540 x 610 mm (H x W x D)**  
allow all types of products to be washed, including GN trays, containers, trays, and cooking utensils.
- **Perforated tank strainer**  
to direct food residue into the *AktivPlus* drain filter system.
- **Aqua-Stop-System ASS** with bottom sheet  
high operating safety due to automatic leaking water control and optimal protection of all incorporated parts.
- **Wash and rinse arms made of stainless steel**  
robust for even the heaviest of commercial applications.
- **ADT - Advanced Dosing Technology**  
secure - reliable - long-lasting



- **Sloping and tented ceiling**  
prevents the washing solution from dripping onto the cleaned items.
- **Drain pump**  
suitable for a waste outlet height of 700 mm.
- **Integrated dosing units**  
including liquid detergent and rinse aid containers.
- **Self-cleaning programme**  
following drain down of the machine.
- **Soft start feature**  
for protection of delicate glassware and crockery.
- **Boiler safety interlock**  
extends the washing programme if the rinse temperature is not achieved – Total hygiene security.
- **Rinse booster pump**  
ensures a constant rinse water volume and temperature, regardless of mains water pressure.
- **Class 'A' air gap**  
complies with all local water authority byelaws.
- **AktivPlus drain filter system**  
gives first class cleaning results due to the multi-filtering of the wash tank water.
- **Rapid regeneration wash tank**  
with only 11 ltr capacity to reduce running costs and to ensure that the machine is always ready for operation.
- **High-quality integral water softener**  
(optional)
- **Water changing programme**  
(optional)

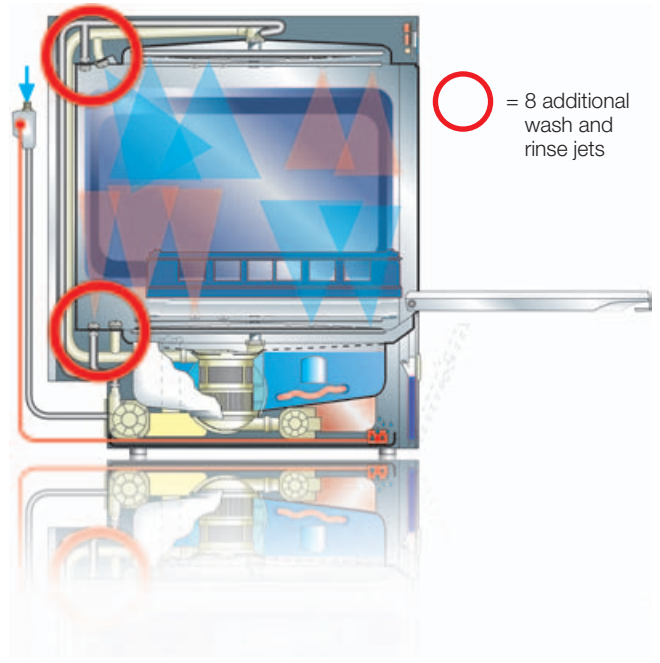

# Advanced full electronic control: Innovation with infrared interface

The most advanced electronic control,  
designed for operating comfort.

The FV 60.2 is provided with our latest *MIKE 2* infrared electronic control system as standard. All three programmes are selected by gently pressing on the appropriate area of the touch sensitive keypad. Operating status and relevant information messaging is indicated on the digital display. International symbols and clearly displayed wash and rinse temperatures make the operation of this machine seem like child's play.

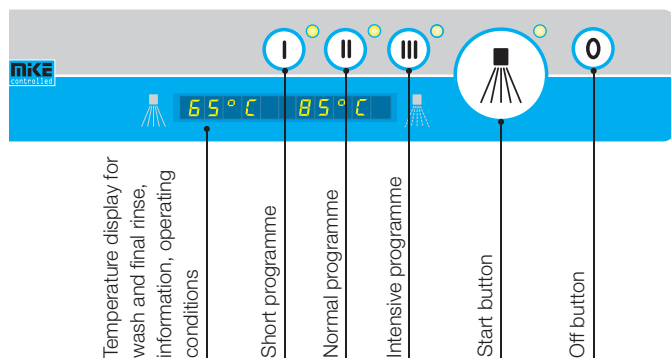

## **MIKE 2 - the latest fully electronic control system with infrared interface for all of our premium class machines**

Innovative control technology for warewashing machines. In connection with the intelligent *M-Commander W*, data can now be easily read, defined, and forwarded online to the plant or customer service for immediate processing. Your advantages: Clear advantages in terms of time, effort, and costs.

The reverse osmosis system.  
Brilliant performance in a  
modular design.

Modular, unique, practical – no ifs, ands or buts. Whether located behind, below, or in a separate area, nothing gets in the way of sparkling cleaning results. The reverse osmosis system may be adapted to any conditions. With its new design and look, this reverse osmosis system with a 98% demineralisation rate offers optimum performance with minimum space requirements. Clean, sparkling, hygienically flawless dishes and glassware for many years.

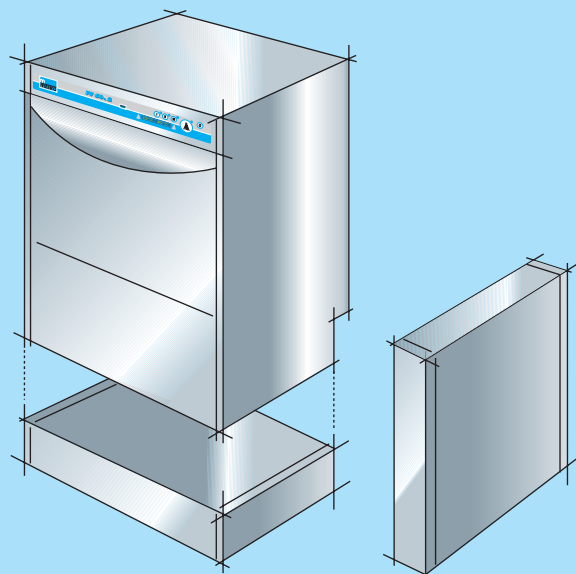

**Utensil washer FV 60.2**  
*GiO MODUL* can be located nearby or in another room.

# Comprising features both useful and beneficial



The clean solution



### **AktivPlus drain filter system**

Tank water is filtered several times ensuring that residues are effectively removed and guaranteeing outstanding cleaning results.

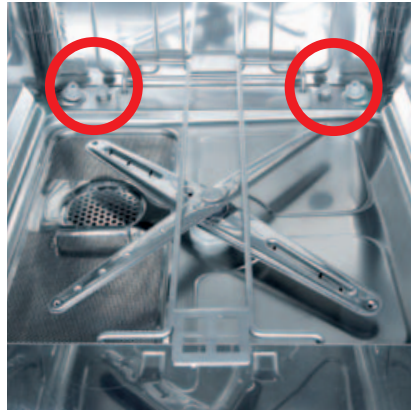

### **View inside the 600 mm deep wash chamber**

With integrated container guide and 8 extra wash and rinse jets at the top and bottom in the rear of the wash chamber (see also machine section).



### **Machine supplied with hose and cable connection kit**

Position the machine and connect to services and you are ready for commissioning and start-up. With the built-in drain pump, a waste discharge height of up to 700 mm is possible.



### **Quality assured**

With the large deep-drawn wash tank, built-in moulded basket runners, and covered edges throughout, this machine is a pleasure to maintain.

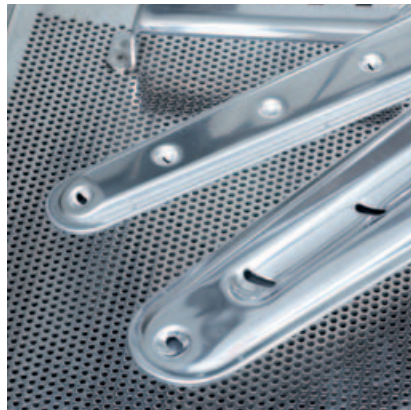

### **Safety first**

Only reliable components and first class materials are used in the manufacture of our machines. This guarantees a high standard of operator security. We also only use stainless steel for our wash and rinse arms to ensure a long working life.

First class the cleaning results with the lowest water consumption per wash cycle

This technology is based on the consistent realisation of the advantages of the MEIKO AktivPlus filter technology, the excellent effectiveness of which provides the suds with a previously unknown level of "purity".

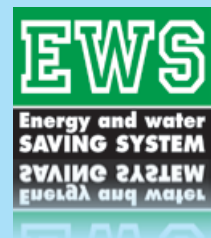

# Dimensions and technical data



The clean solution

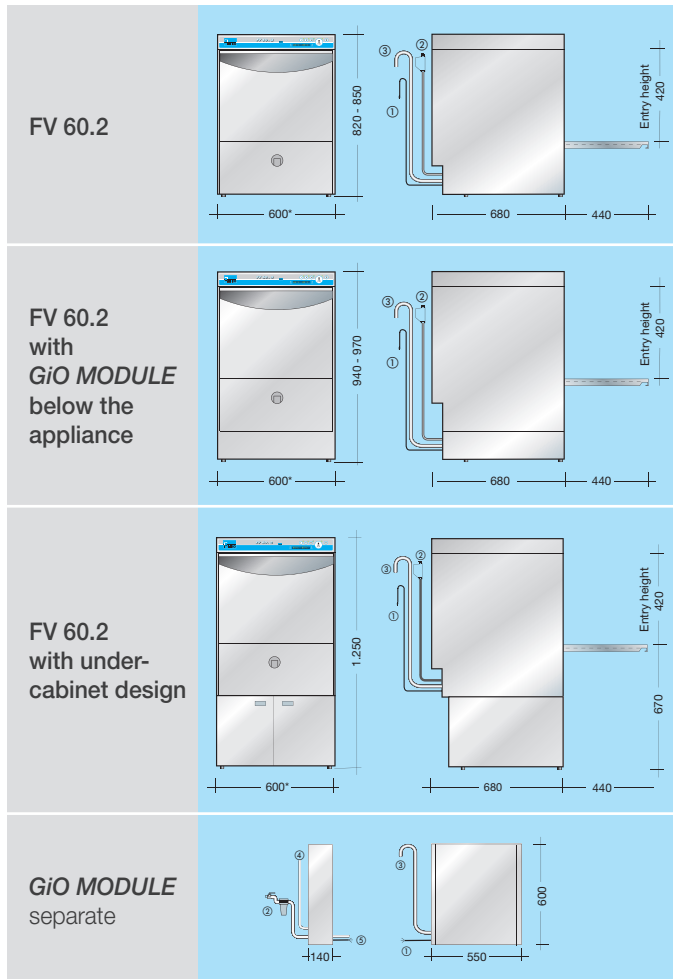

\* 680 mm with built-in water softener AktivClean

## Programme cycles

Short programme	= 90 sec (400 V)	120 sec (230 V)
Normal programme	= 120 sec (400 V)	180 sec (230 V)
Intensive programme	= 240 sec (400 V)	240 sec (230 V)

	FV 60.2	230 V	400 V
<b>Basket dimensions</b>	mm	500 x 500	
<b>Containers and inserts</b>	mm	600 x 400 (500)	
<b>Theoretical basket capacity*</b>	up to baskets/hour	30/22/15	40/30/15
<b>Pump motor</b>	kW	0.55	
<b>Tank capacity</b>	ltr.	11	
<b>Final rinse**</b>	litres/baskets	2.6 - 3.7	
<b>Tank heating</b>	kW	2.0	1.3
<b>Built-in boiler</b>	kW	3.0	7.5
<b>Total connected load</b>	kW	3.7	9.5

\* For connection to cold water and/or short basket exchange times, the wash cycles may increase to achieve hygienic final rinse temperatures.

The programme cycles extend within the water changing programme.

\*\* Adjustable via power rinse jets.

## Electrical installation:

Electrical connection: ① Alternating current 1 NPE, 230 V, 50 Hz; three-phase current 3 NPE, 400 V, 50 Hz. With integrated AktivClean water softener (option), total supply increases by 0.25 kW. Circuit complies with the requirements of the VDE (German Association of Electrical Engineers).

## Water installation:

The machines can be connected directly to the fresh water supply without the use of intermediate safety fixtures ②. Minimum flow pressure 0.6 bar, maximum pressure 5 bar. Installation requirements of EN 1717 are to be observed. 3/4" drain. Wall-mounted, on-site drain should be max. 700 mm high ③. Length of connection cables from the machine is approx. 1.4 m.

## GiO MODULE (all models):

Cold water (max. 35 °C). Minimum flow pressure 1 bar, maximum pressure 5 bar. Conductivity of raw water <1000 µS/cm. Total water hardness max. 28 °dH (German hardness). Including connection kit: check valve, pressure regulating valve, filter 10 µm including activated carbon, safety equipment "HD" (backflow preventer and pipe aerator). Installation requirements of EN 1717 must be observed. Connection length approx. 3 m. Connection kit of the appliance with reinforced hose (without AquaStop). Concentrate drain 1/2" ④, length approx. 2 m. Permeate and electrical cables between machine and separate GiO MODULE approx. 3 m ⑤.

(1 bar = 100 kPa) (1 °dH approx. 0.18 mmol/l CaCO<sub>3</sub>)



In accordance with the hygiene requirements of DIN 10511-H for commercial glasswashing, DIN 10512 for commercial dishwashing and DIN 10522 for professional warewashing of reusable boxes.



150.076.01.07.13/GB/FD/2500 We reserve the right to make changes as part of product improvements.