

Indigo® SpaceMaker™ Ice Cube Machine

Indigo® SpaceMaker™ Ice Cube Machine

Models

- ID0906W-261V
- IY0906W-261V



ID0906W-261V
As shown with M4 Marine bin
(recommended)

Marine Ice Machine Features

New Indigo® SpaceMaker™ puts the utilities connection through the top panel allowing the machine to come in contact with the back and side walls saving valuable space in the galley.

- Standard Indigo feature set with internal communication system that continually monitors refrigeration and sub-system controls 24/7.
- Front facing evaporator allows access to the Food zone for easy cleaning without removing the top lid.
- Isolation switch immediately cuts power to the entire unit.
- Completely sealed unit, top, front, back, top and sides.
- Meets USPHS and NSF specifications
- Top and Side panels designed to be removable even when fixed to the bulkhead, allowing easy access for servicing

Warranty

- 5-year parts-and-labor on evaporator.
- 5-year parts and 3-year labor on compressor.
- 3-year parts-and-labor on all other components.



Top access ports



Easy access control panel



M4 Marine bin (recommended)

Ice Shape



Half Dice
3/8" x 1/8" x 7/8"
(.95 x 2.86 x 2.22 cm)



Dice
7/8" x 7/8" x 7/8"
(2.22 x 2.22 x 2.22 cm)



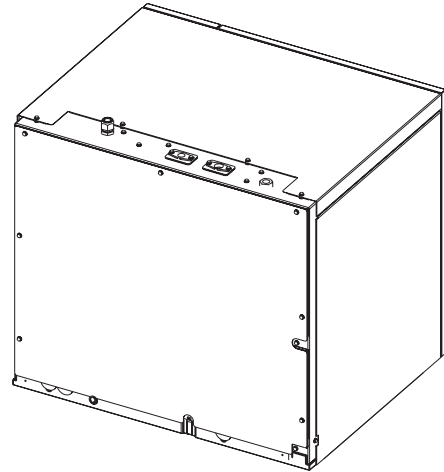
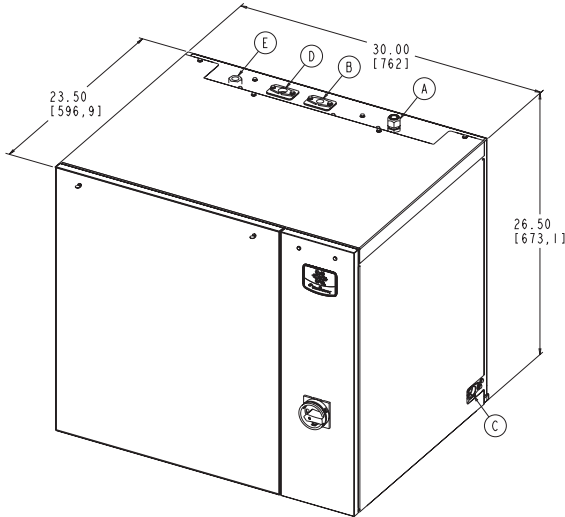
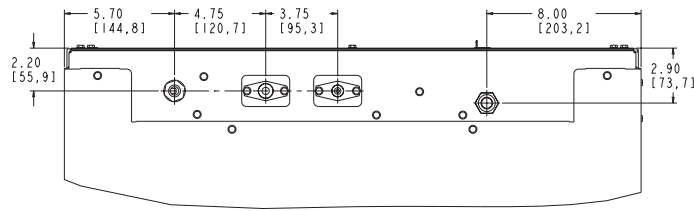

- (A) Electrical Entrance (2) Options
- (B) 3/8" (0.95 cm) F.P.T. Ice Making Water Inlet
- (C) 1/2" (1.27 cm) F.P.T. Ice Making Water Drain
- (D) 1/2" (1.27 cm) F.P.T. Water Condenser Outlet
- (E) 3/8" (0.95 cm) F.P.T. Water Condenser Inlet

Series 906		Ice Machine Electric		Ice Machine Operating Limits	
ID-0906W	Dice Size	Electricity	208-230 v	Ambient Temperature	40 to 110 F (4.4 to 43.3C)
IY-0906W	Half Dice Size	Phase	Single	Potable Water Temp.	40 to 90 F (4.4 to 32.2C)
26.5" H x 30.0" W x 24.5" D		Cycle	60 Hz	Water Pressure	Min 20 psi (137.9 kPA)
76.2 H x 62.2 W x 67.3 D cm		Max fuse size	20 amp		Max . 80 psi (551.1kPA)
Approx. Net Wt.	200 lbs/90.7 kg	Min Ampacity	11.2 A	Condenser Water	Min 20 psi (137.9 kPA)
Approx. Gross Wt.	215lbs/97.5 kg	Machine Rating	1195.2 W		Max. 150 psi (1,034.2kPA)

Ice Production 24hours								
Model	Ice Shape	70 Air/50F Water		90 Air/70F Water		kWh/100 lbs ice	gal/100 lbs ice	
ID0906W	dice	839 lbs	381 kg	701 lbs	318 kg	4.35	19 Gal.	71.9 L
IY0906W	half-dice	879 lbs	399 kg	786 lbs	357 kg	4.04	19 Gal.	71.9 L

Water Cooled Condenser Water usage /100 lbs /45.4 kgs. of ice 150 gal/568L

This product is hermetically sealed and contains fluorinated greenhouse gas R404a.

Note: Placing the I-906 ice machine on a non-Manitowoc ice bin, requires installation of an ice deflector (PN. K-00347)

Welbilt reserves the right to make changes to the design or specifications without prior notice.